



**DASERS**  
**DASERS**  
MANUFACTURA DASERS  
S. DE R.L. DE C.V.

Portafolio de proyectos  
manufactura

# MANUFACTURA DASERS S DE RL DE CV



SOMOS UNA EMPRESA MEXICANA LOCALIZADA ESTRATEGICAMENTE EN VILLAGRAN GUANAJUATO, CON LA FINALIDAD DE ATENDER LAS NECESIDADES DE MANUFACTURA DE LAS EMPRESAS DE ESTA REGION Y SUS ALREDEDORES

CONTAMOS CON UN EQUIPO DE MAS DE 10 AÑOS DE EXPERIENCIA EN LA FABRICACION DE COMPONENTES DEL SECTOR AUTOMOTRIZ

SE CUENTA CON UN EQUIPO DE ESPECIALISTAS EN DISTINSTAS AREAS MANUFACTURA, DISEÑO, INTEGRACIÓN Y PUESTA EN MARCHA

# DISPOSITIVOS PARA CENTROS DE MAQUINADO PROYECTO LLAVE EN MANO:

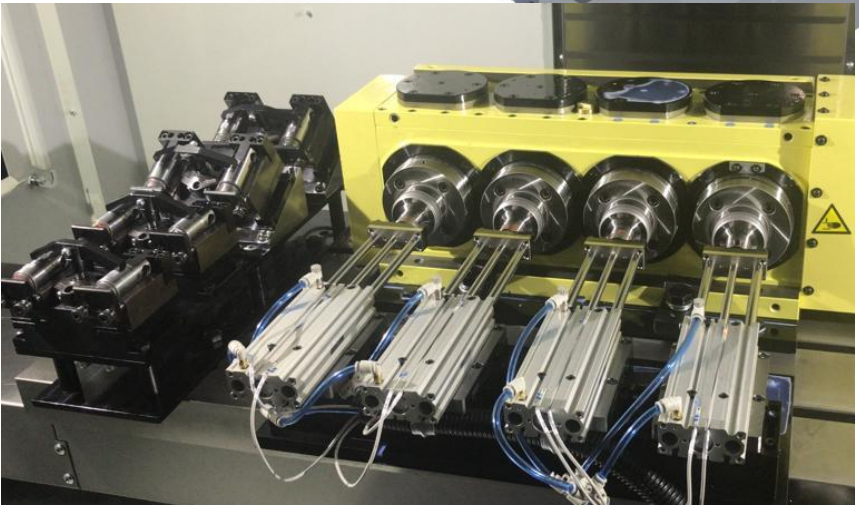
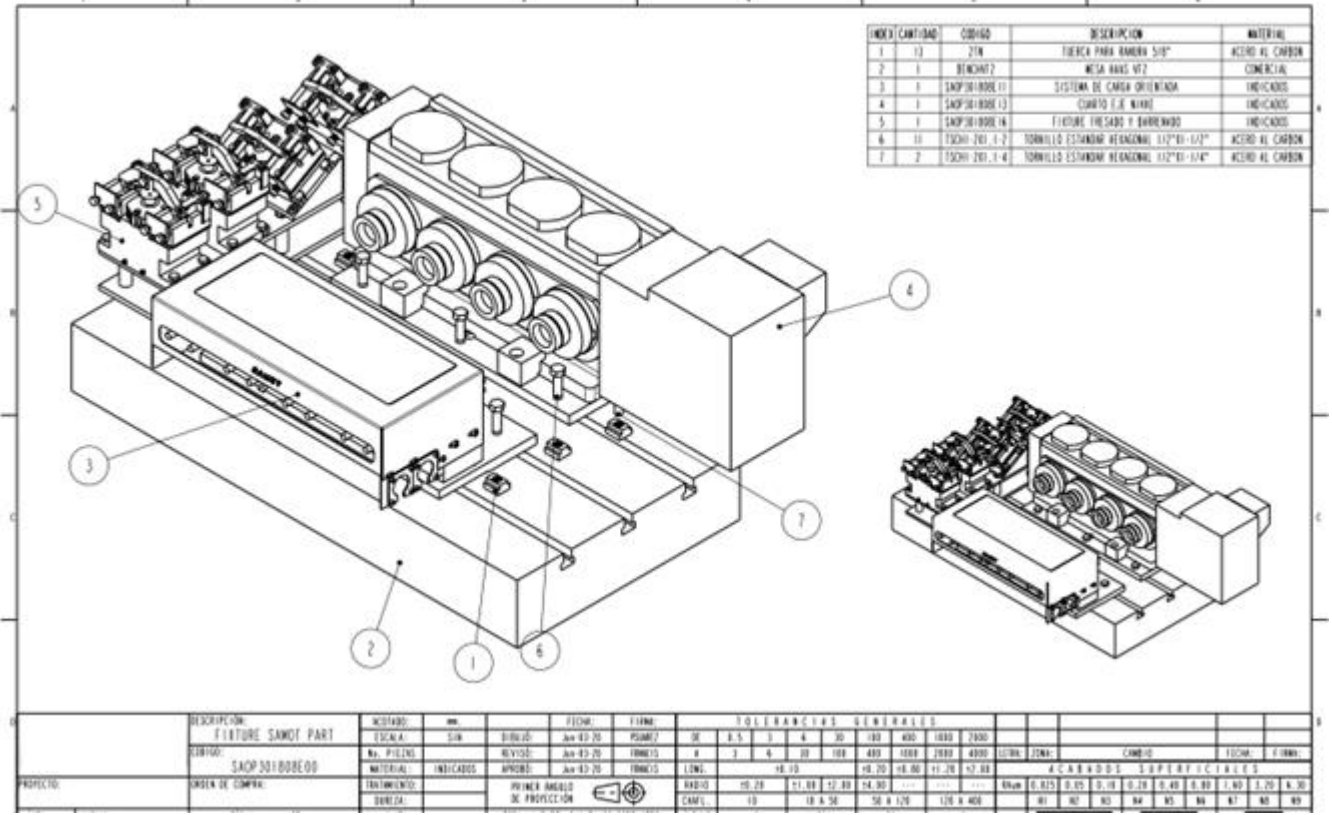
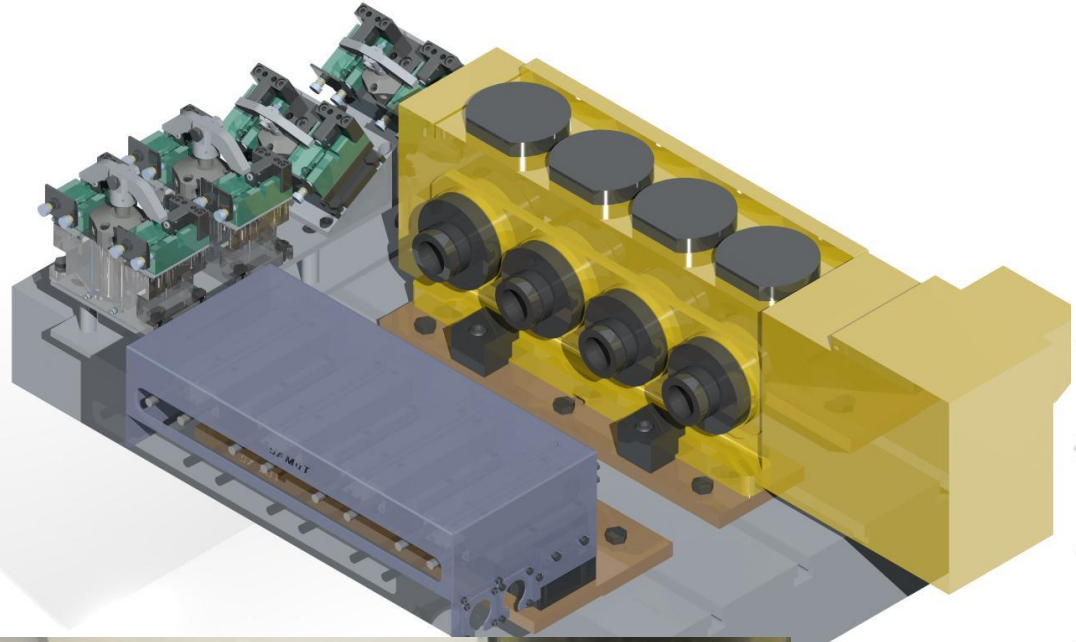

# DISPOSITIVOS PARA CENTROS DE MAQUINADO:

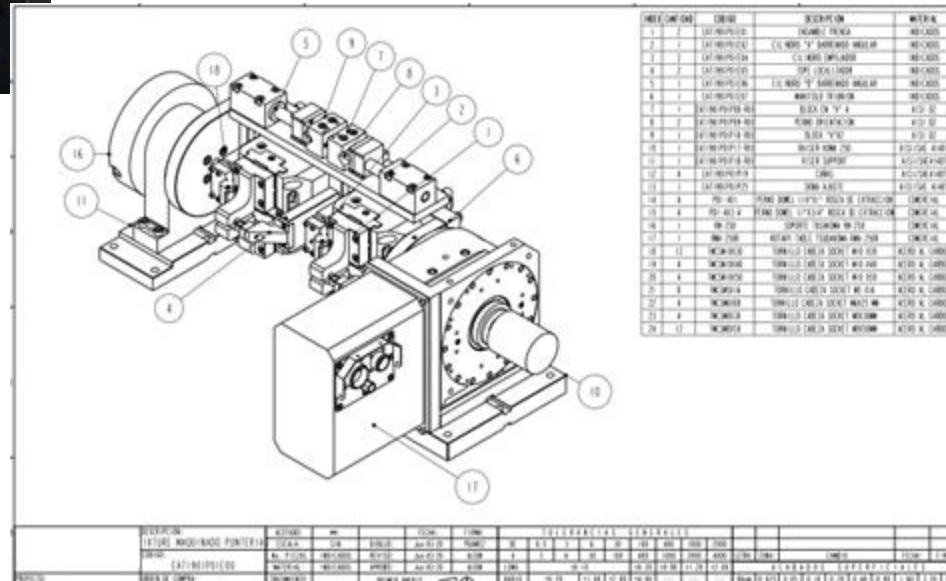
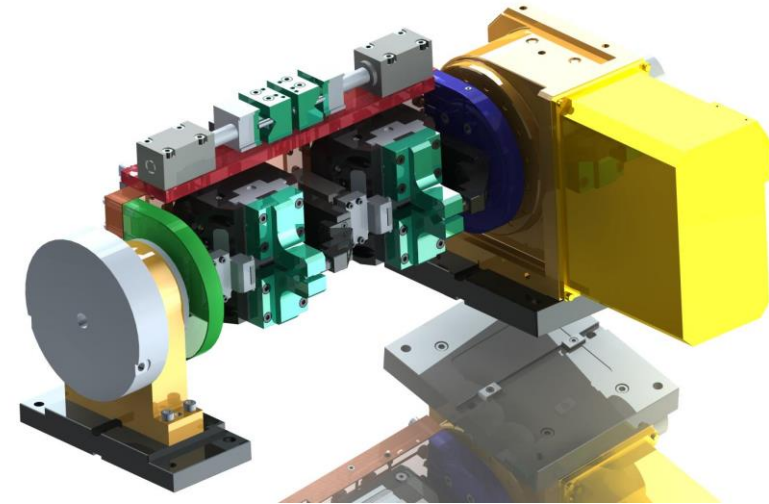
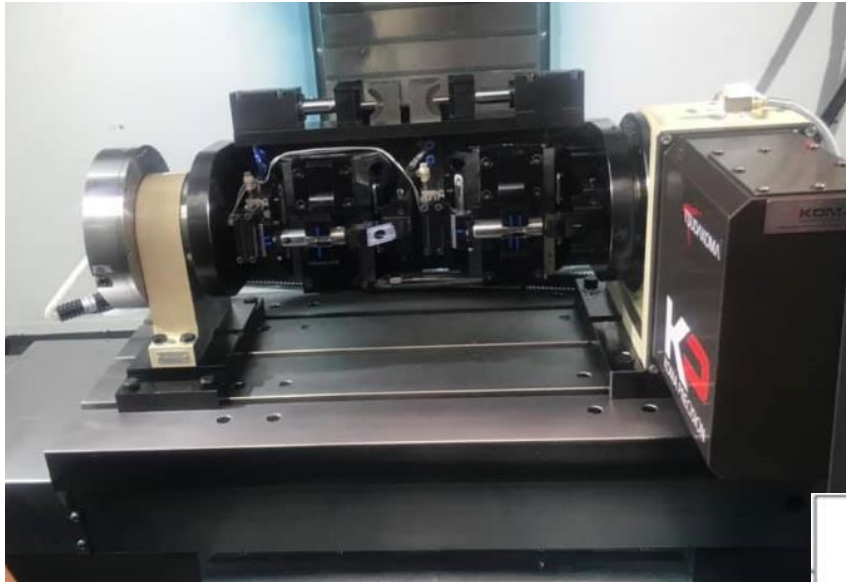

# DISPOSITIVOS PARA CENTROS DE MAQUINADO:

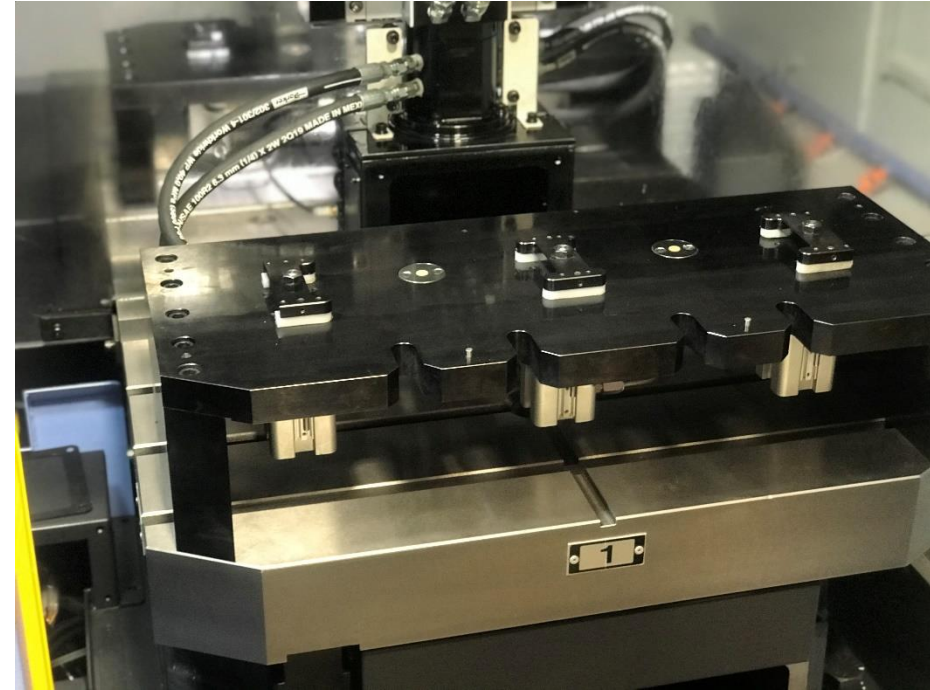
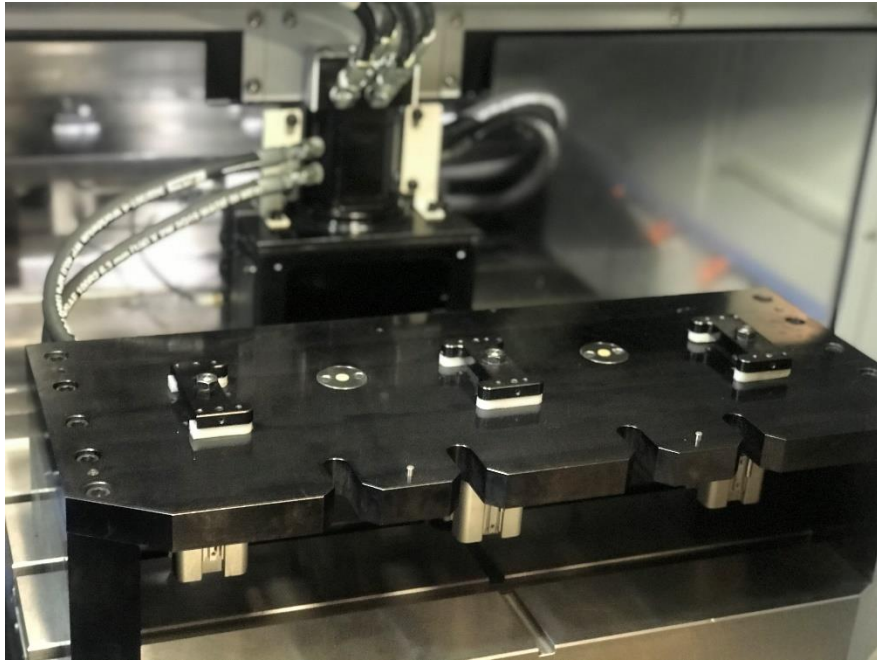

# DISPOSITIVOS PARA CENTROS DE MAQUINADO:

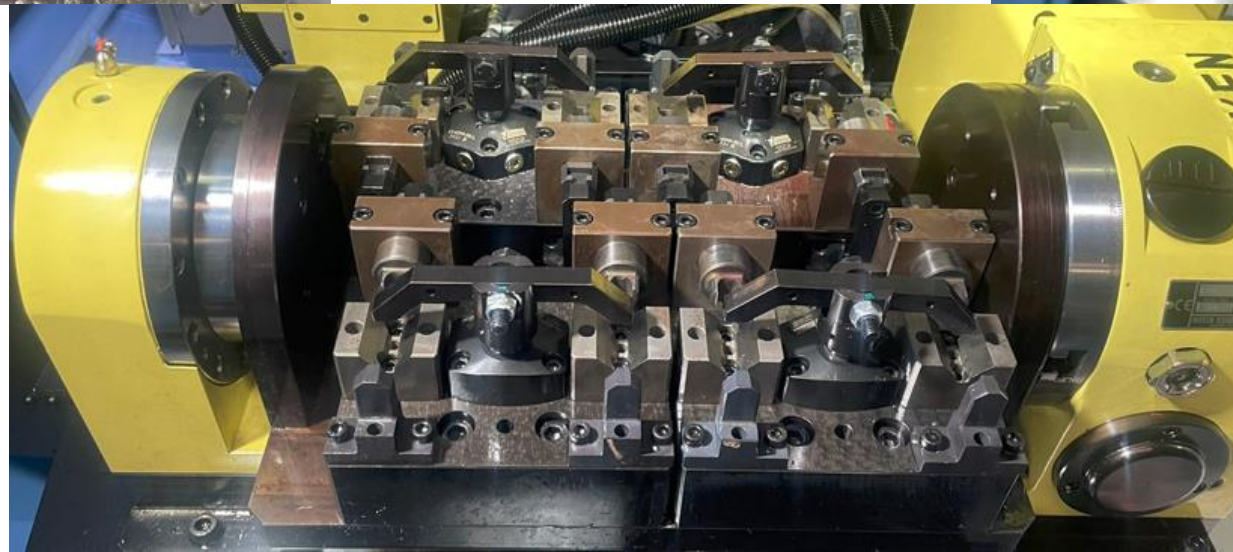
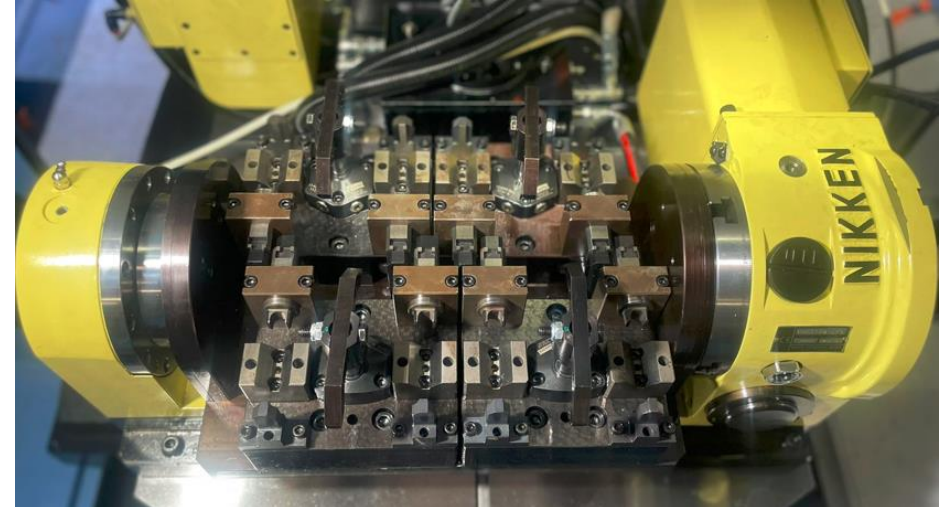
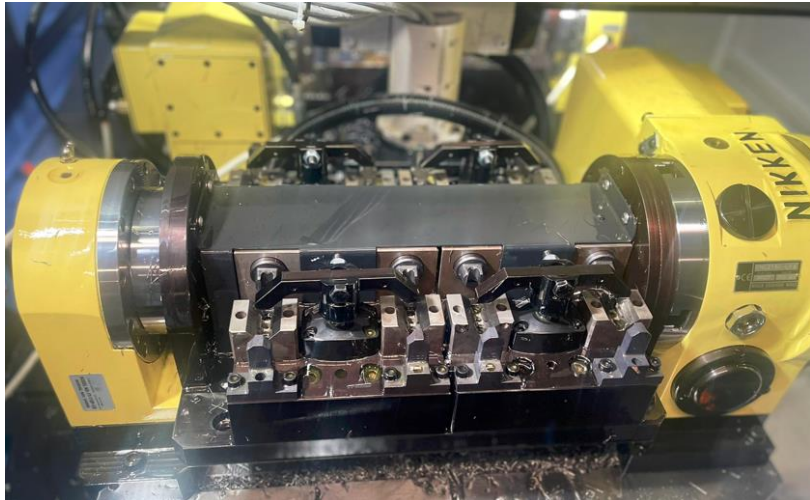

# DISPOSITIVOS PARA CENTROS DE MAQUINADO:

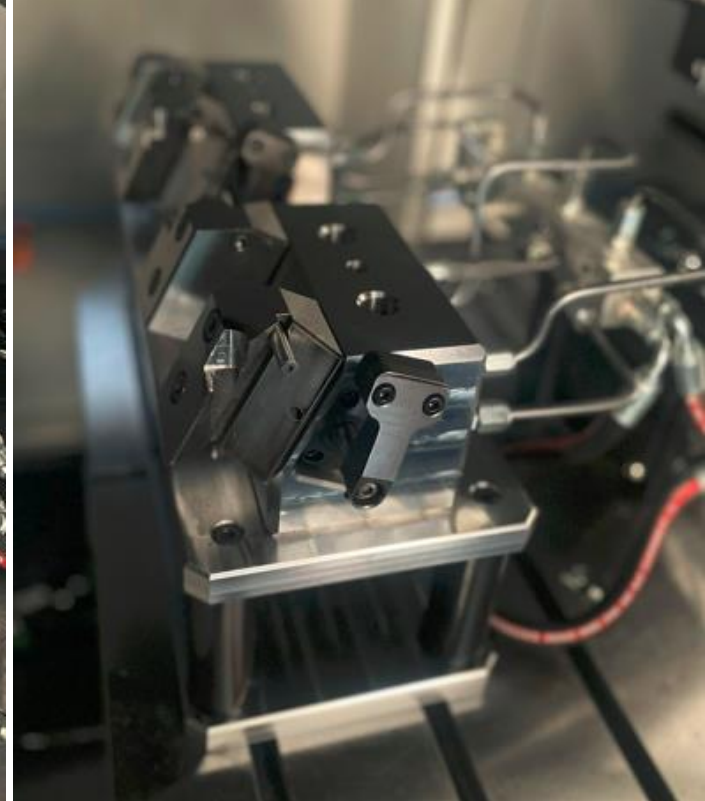
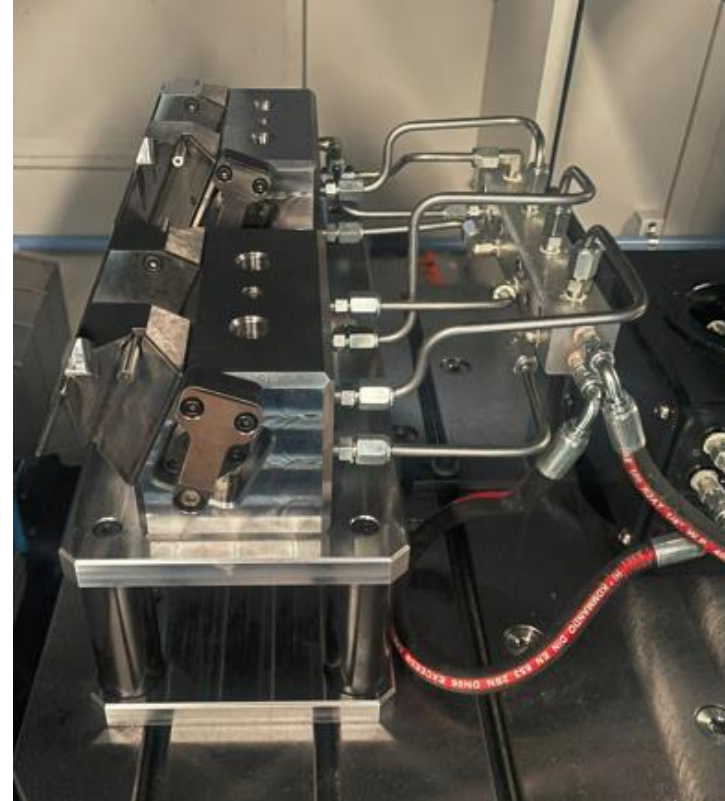

# DISPOSITIVOS PARA DEPARTAMENTO METROLOGIA:

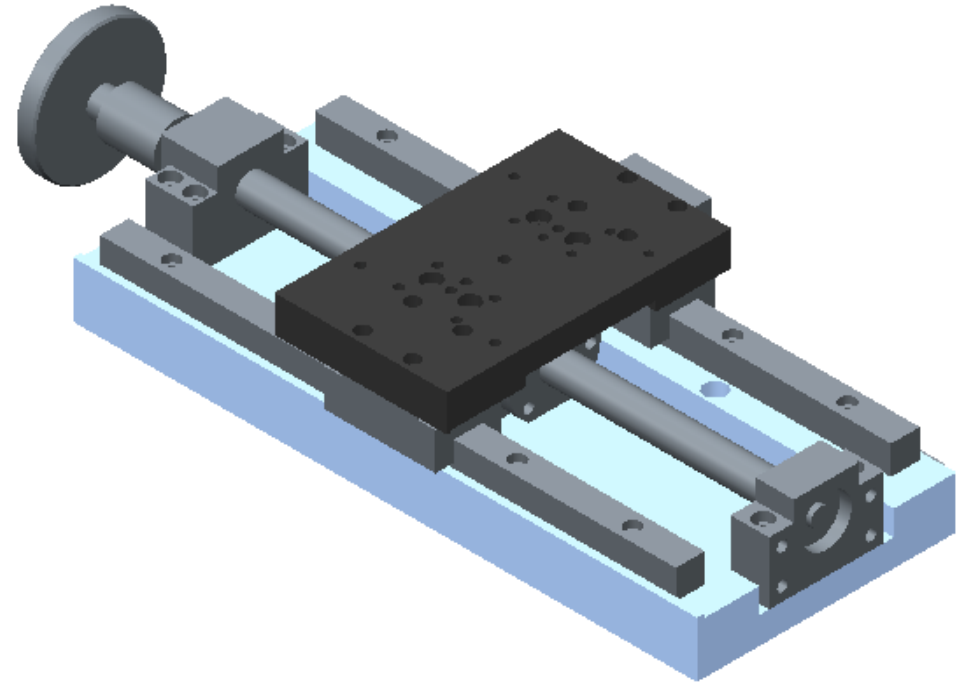
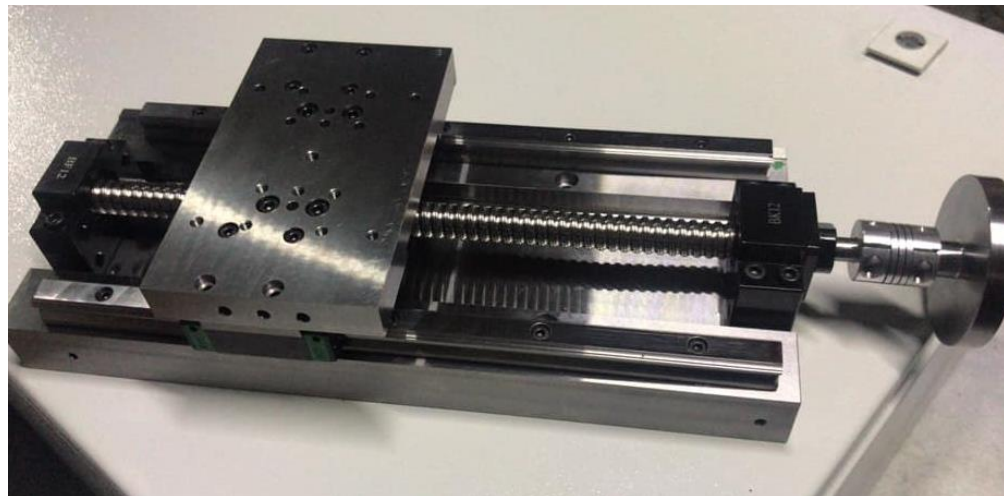
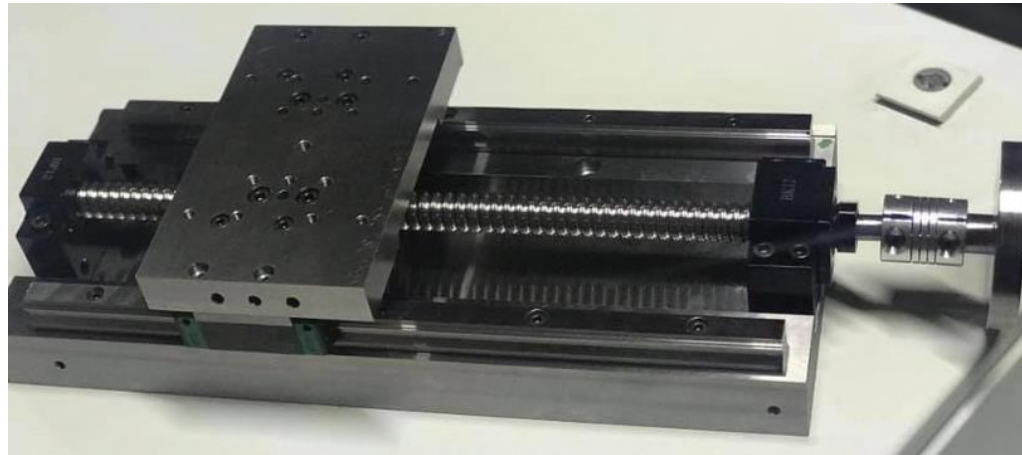



# DISPOSITIVOS PARA DEPARTAMENTO METROLOGIA:

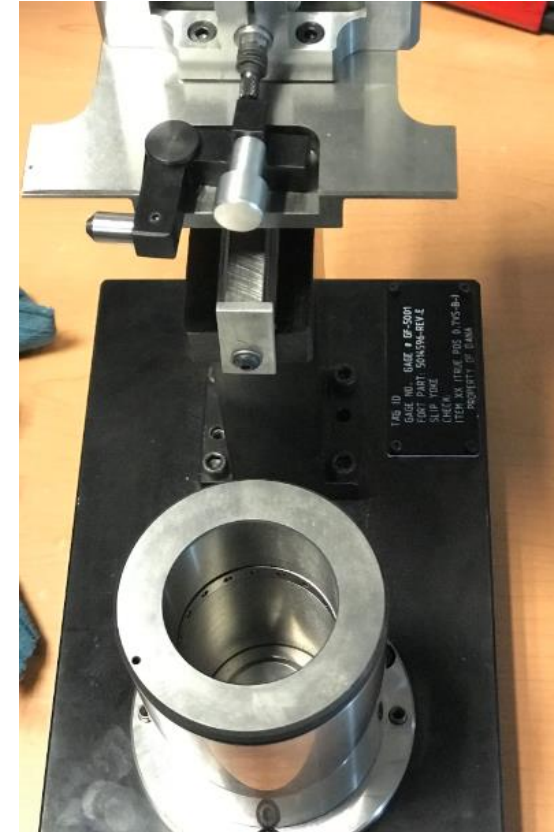
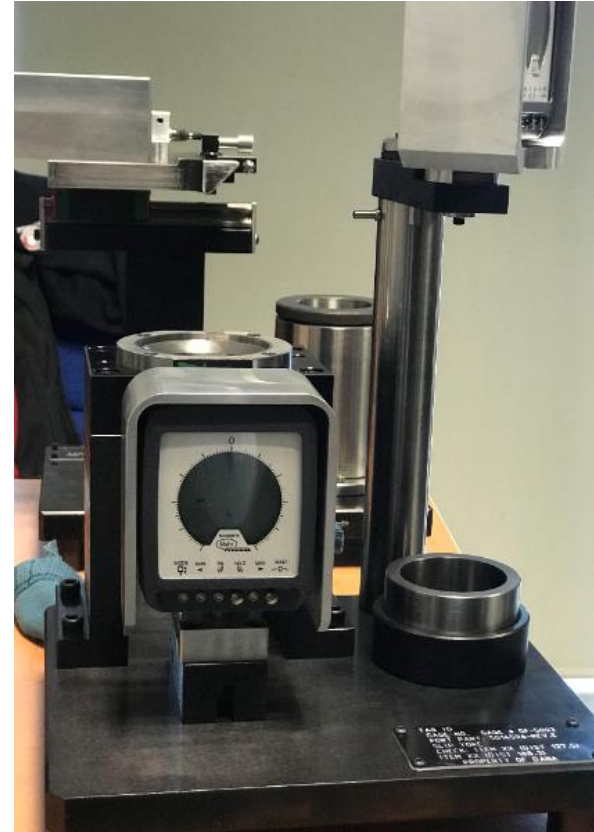

# TOP TOOLING EN POWER CHUCKS DIFERENTES MARCAS:

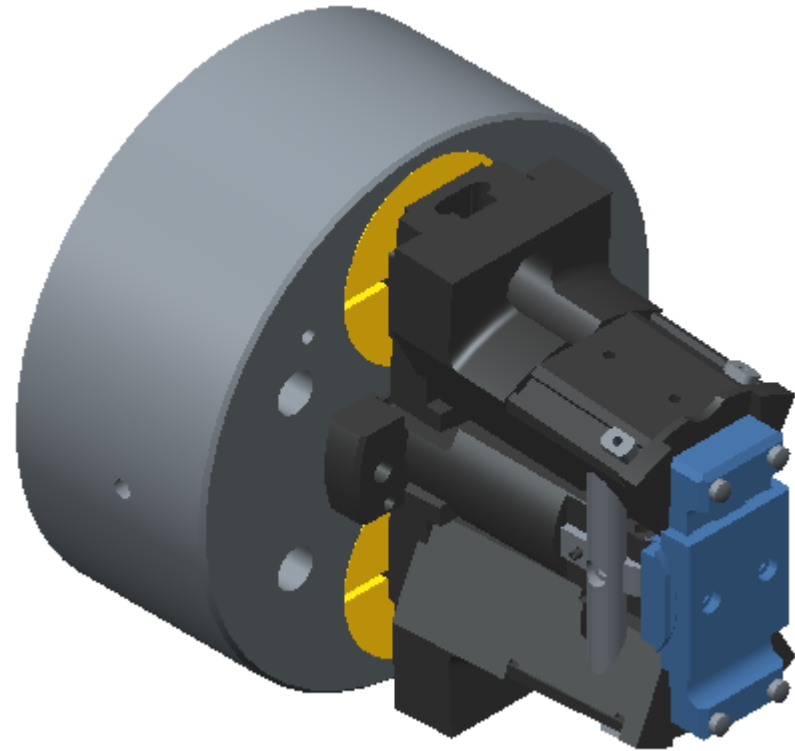
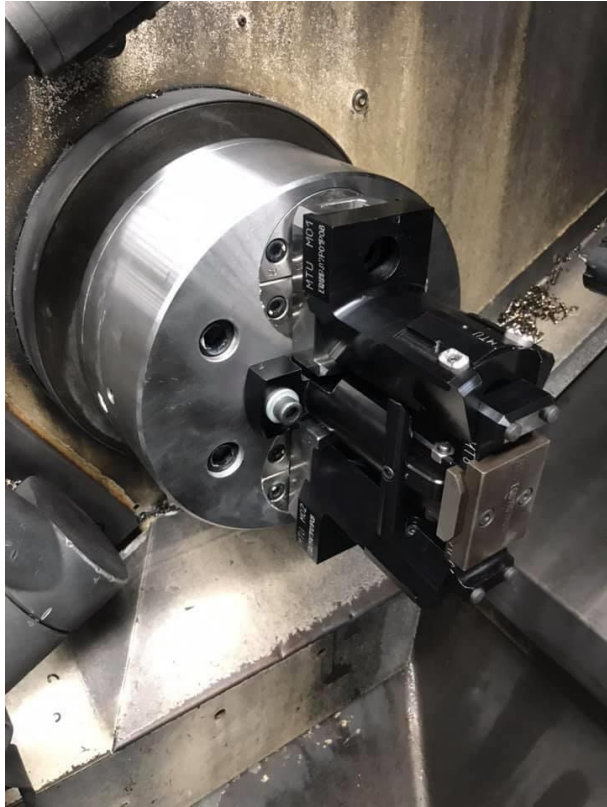

# TOP TOOLING EN POWER CHUCKS DIFERENTES MARCAS:



# PAILERIA Y ESTRUCTURAS:



GUARDA PERIMETRAL  
PARA ALMACEN 4 METROS  
DE ALTURA

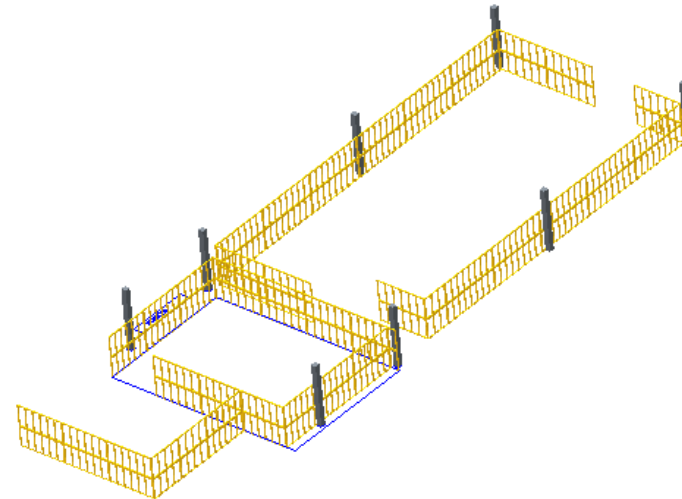

# PAILERIA Y ESTRUCTURAS:



GUARDA PARA ROBOTS

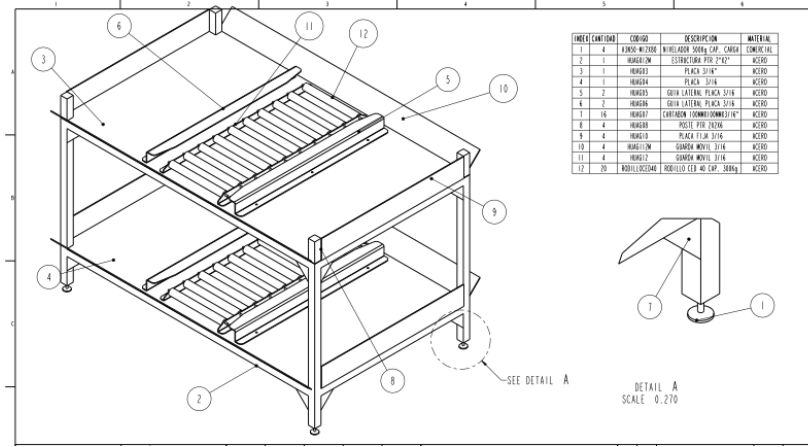

# Servicios:

Diseño y fabricación de dispositivos a medida, cumpliendo con los requerimientos especificados por el Usuario

Racks para moldes

Racks para troqueles

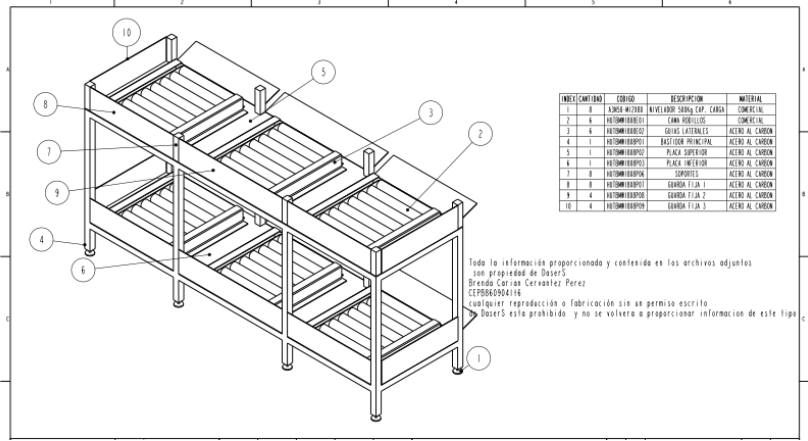
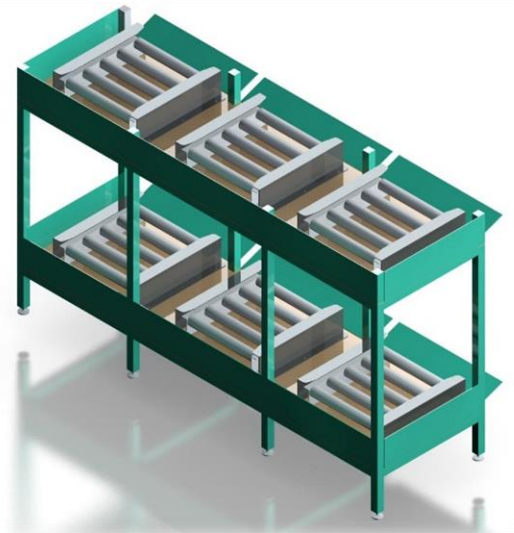



## Servicios:

Diseño y fabricación de dispositivos a medida, cumpliendo con los requerimientos especificados por el Usuario

CAMAS DE RODILLOS

# CARROS DE TRANSPORTE DE MATERIAL





# MAQUINARIA Y EQUIPO

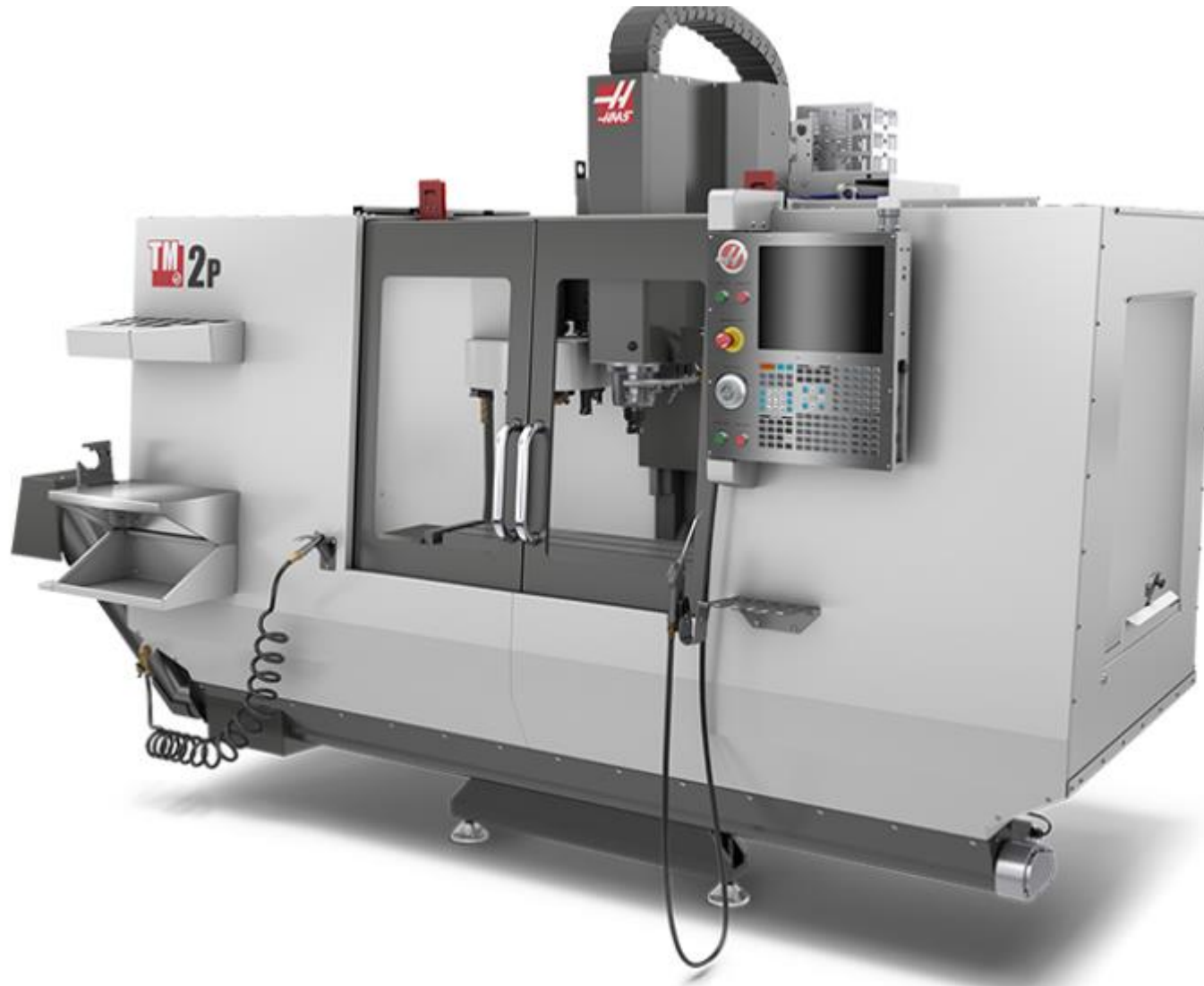

## RECORRIDOS

	S.A.E	METRIC
Eje X	40.0 in	1016 mm
Eje Y	16.0 in	406 mm
Eje Z	16.0 in	406 mm
Nariz del husillo a la mesa (~ máx.)	20.0 in	508 mm
Nariz del husillo a la mesa (~ mín.)	4.0 in	102 mm

**CENTRO DE  
MAQUINADO  
TM-2P MODELO  
2020**

# MAQUINARIA Y EQUIPO

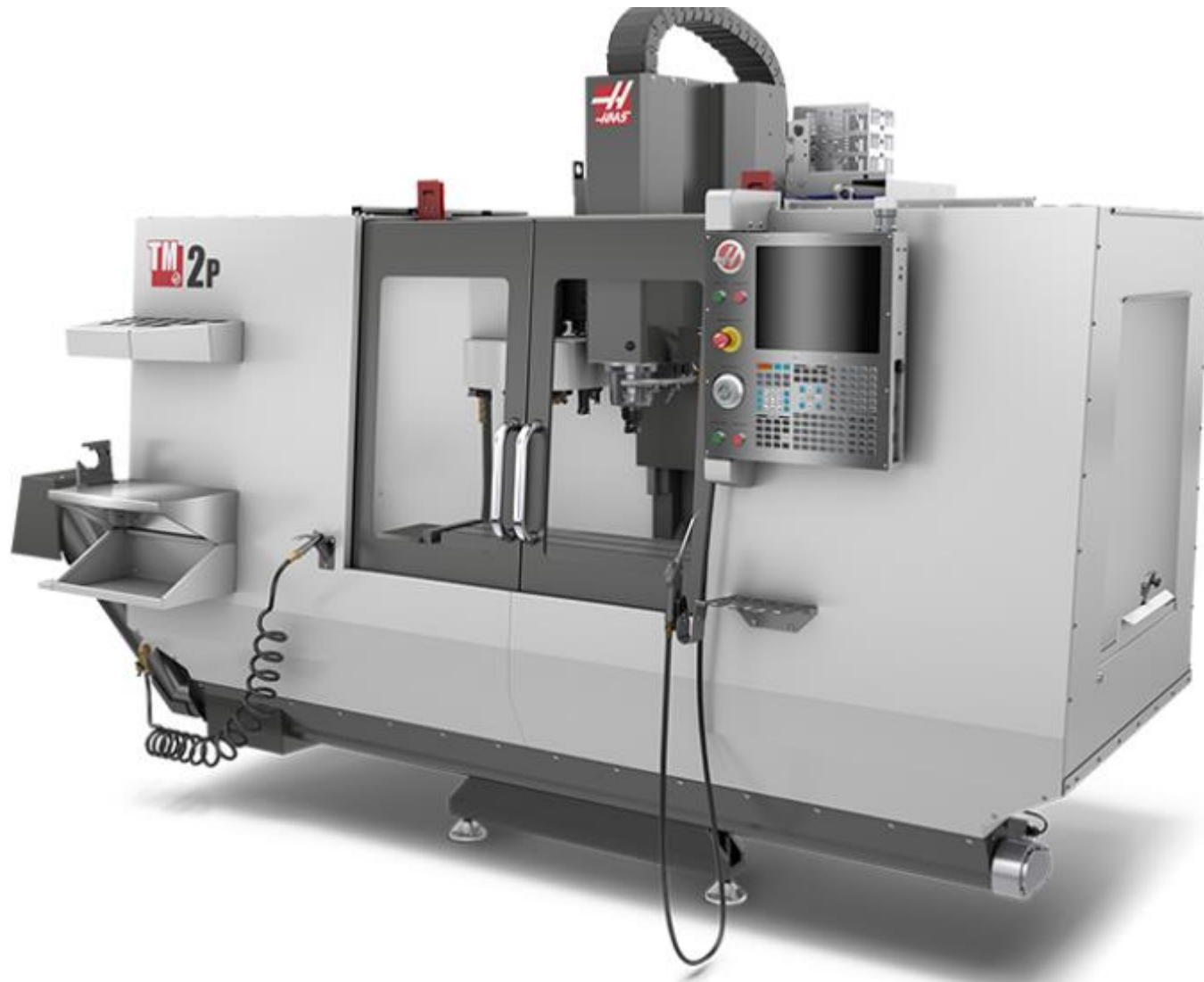

EQUIPADO CON  
SISTEMA WIPS  
RENISHAW



# MAQUINARIA Y EQUIPO



## CENTRO DE MAQUINADO NEWAY MODELO 2021

TAMAÑO DE MESA 1100  
X520 RECORRIDO EN  
EL EJE "X" 1000MM  
EJE "Y" 520MM  
EJE "Z" 560MM  
HUSILLO CAT 40  
10 000 RPM  
MAGAZINE PARA 24  
HERRAMIENTAS

# MAQUINARIA Y EQUIPO



## TRAVELS

	S.A.E	METRIC
X Axis	64.0 in	1626 mm
Y Axis	32.0 in	813 mm
Z Axis	30.0 in	762 mm
Spindle Nose to Table (~ max)	34.0 in	864 mm
Spindle Nose to Table (~ min)	4.0 in	102 mm

**CENTRO DE  
MAQUINADO VF-6  
MODELO 1995  
RETROFIT 2016**

# MAQUINARIA Y EQUIPO



FRESADORA  
CONVENCIONAL SCCALA  
AÑO 2013

FRESADORA  
CONVENCIONAL GRAT  
MACHINE TOOL AÑO 2009

TALADOR FRESADOR AL-  
HAWK  
AÑO 2015

# MAQUINARIA Y EQUIPO



RECTIFICADORA  
PLANA MALCUS  
1000X400MM

RECTIFICADORA  
PLANA BROWN AND  
SHARPE  
MICROMASTER 618

# MAQUINARIA Y EQUIPO



**TORNO  
CONVENCIONAL  
COLCHESTER**

# MAQUINARIA Y EQUIPO



TORNO CNC  
HEADMAN  
MODELO CK6130  
MODELO 2010



# MAQUINARIA Y EQUIPO



SISTEMA DE  
CORTE CON  
PLASMA CNC  
CON CAPACIDAD  
DE ¾" ACERO AL  
CARBON

# MAQUINARIA Y EQUIPO



NAVE CON AREA  
DE 476 METROS  
CUADRADADOS

# NUESTROS CLIENTES



HUTCHINSON®



**CROTEK**  
ENGINEERING & AUTOMATION



CENTRIC

**PRESOTEC**  
*"Team Key CNC - Líder en Soluciones Rentables"*



**SIEMENS**